

# ENXXX03TI050KW400V

Conversion set for vans and mini buses

Our conversion sets for delivery vehicles with a DMC of up to 3,5T, vehicles with a DMC of up to 7,5T and mini buses can be implemented in two solutions: vehicles with front and rear axle drive. The system consists of vehicle control unit, power electronics unit, lithium-ion battery and engines.

## Conversion set delivery range:

- ✓ Electric motors
- ✓ Converters
- ✓ Vehicle control modules
- ✓ Onboard chargers
- ✓ AC/DC chargers
- ✓ 12V or 24V DC/DC chargers
- ✓ HV or LV beams
- ✓ Lithium-ion batteries

## Specification of the set:

- Highly integrated system
- Light construction
- Trouble-free integration with the vehicle
- Powering of supporting devices
- Maximum power up to 120 kW
- Permanent magnet motor
- Security level : IP 67
- Product designed in accordance with the requirements of the automotive industry
- EMC electromagnetic compatibility
- High impact, vibration and corrosion resistance
- Cooling type: liquid cooling (40/60 - water/glycol)

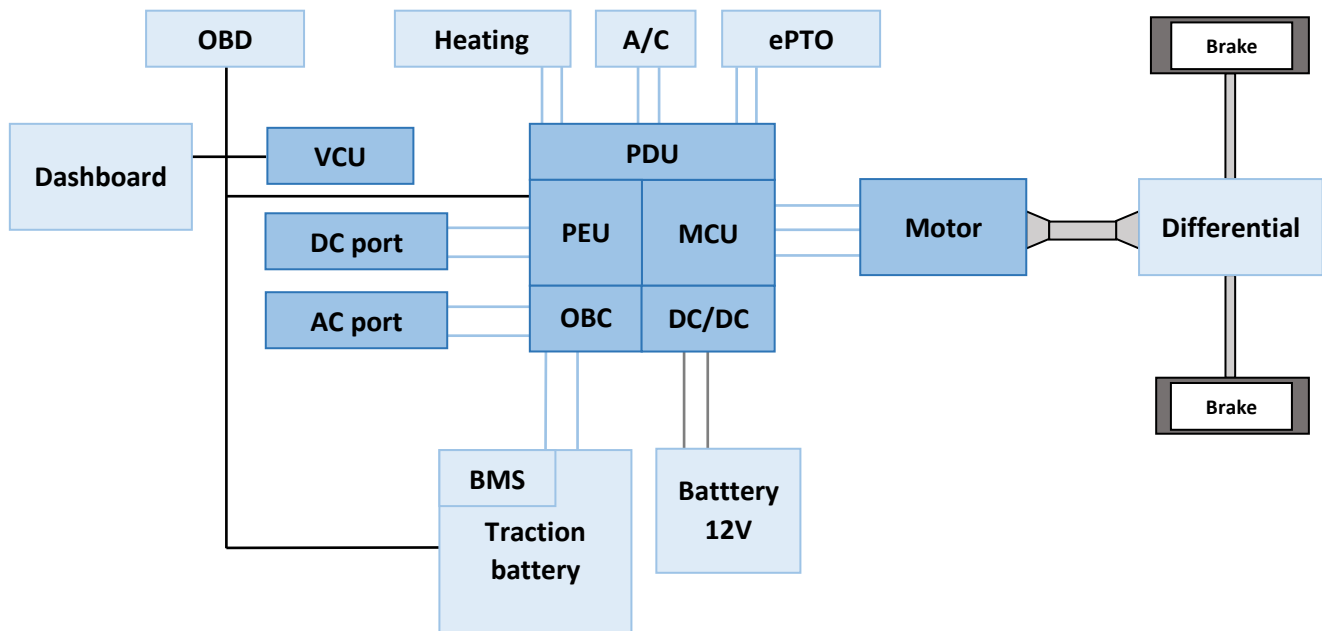

**Parts set:**

OFFERED PRODUCTS:	QUANTITY:	PRODUCT PICTURE:
<p>Electric motor with gearbox and differential 50kW EN002050KW</p>	<p>1</p>	
<p>Power electronics (OBC 6kW, DC/DC 2.5kW,PDU) EN60LTPIC-F21</p>	<p>1</p>	
<p>Vehicle control unit ENDN67VCU-41B</p>	<p>1</p>	
<p>Onboard chargers 22kW (optional 11kW) EN22K2</p>	<p>1</p>	
<p>AC/DC chargers 30kW EN30K2</p>	<p>1</p>	
<p>HV or LV beams</p>	<p>1</p>	
<p>Lithium-ion batteries 40kWh (other capacities available) EN018BW040K400V102AhNMC</p>	<p>1-3</p>	
<p>Drivers display ENDIS12v1</p>	<p>1</p>	
<p>Gear shift selector</p>	<p>1</p>	